

THE TOP 12 INCHES OF THE 1" X 40" ANCHOR BOLTS SHALL BE HOT DIP GALVANIZED. ANCHOR BOLTS SHALL BE THREADED A MINIMUM OF SIX INCHES WITH UNC 8 THREAD. TWO, ONE INCH UNC 8 GALVANIZED HEX NUTS MEASURING 1-5/8" ACROSS THE FLATS, AND TWO GALVANIZED PLATED HOT DIPPED STEEL FLAT WASHERS (MINIMUM 2-1/2" OUTER DIAMETER AND 3/16" THICK) SHALL BE PROVIDED FOR EACH ANCHOR BOLT.

TOP VIEW

BOLT CIRCLE DIAMETER AS SPECIFIED

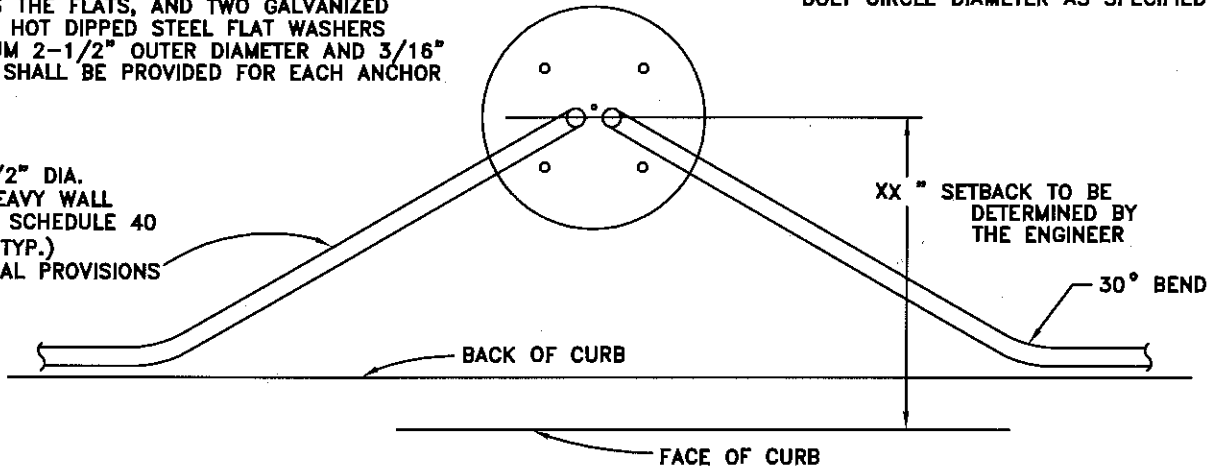

CONDUIT:

- MIN. 1-1/2" DIA.
- TYPE II HEAVY WALL RIGID PVC SCHEDULE 40 CONDUIT (TYP.)
- SEE SPECIAL PROVISIONS

GROUND ROD TO BE INSTALLED AS SHOWN OR AS DIRECTED BY THE ENGINEER (5/8" DIAMETER).

SIDE VIEW

4" TO 4 1/2" THREAD EXPOSURE APPLY SPRAY GREASE TO THREADED SURFACES.

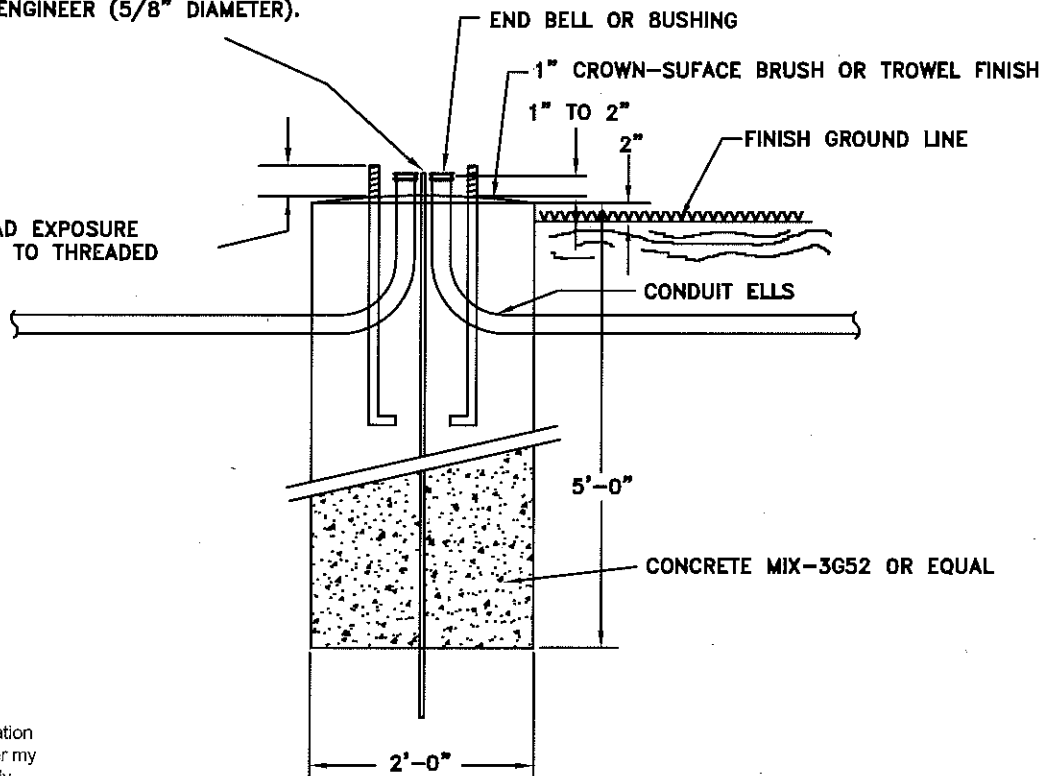

I hereby certify that this plan, specification or report was prepared by me or under my direct supervision and that I am a duly Licensed Professional Engineer under the laws of the State of Minnesota

*Brian P. Vitek*  
 Brian P. Vitek

Date 12/3/15 Lic. No. 40444

APPROVED 12-3-15  
*J. P. Myle*  
 CITY ENGINEER

CITY OF ST. PAUL  
 DEPARTMENT OF PUBLIC WORKS  
 LIGHT STANDARD FOOTING DETAIL  
 SOD/SOIL SURFACE

Date of Revision  
 DEC 2015

Standard Plate No.  
 5008G