



Application Requirements for New Detached Garage

- Completed Building Permit Application and Home Owner Affidavit (if applicable)
- Site plan showing entire property boundary and location of all structures including the proposed location of the new garage. Show the dimensions of the garage and proposed distances from property lines. *Note: if applicant is unable to find property markers a licensed surveyor will be required to locate them.*
- Construction Plans including:
 - Plan view/ framing plan including:
 - Overall dimensions and window/ door sizes and locations – include header sizes.
 - Roof framing information – if hand framing include framing plan, if using manufactured trusses specifications will be required on site.
 - Front, rear and side elevations to scale:
 - Show height from grade to mid-point of the roof
 - Show window/ door locations and dimension of roof overhangs (if applicable)
 - Wall Section including:
 - Foundation/ slab material, thickness and reinforcing
 - Sill plate material and anchor specifications
 - Stud size and spacing
 - Sheathing and siding material. *Note: Separate permit required for Stucco.*
Note: Fire-resistant construction may be required per section R302 Minnesota State Residential Code
 - Roof framing size/spacing, roof sheathing and roofing material
 - Wind bracing plan per section R602 Minnesota State Residential Code. *Note: Include additional detailing at garage door façade if necessary.*
- Garage door must be constructed to resist 90mph wind load, documentation required on site.
- Separate trades permits may be required.
- Additional requirements may apply if property is located in a historic district or zoning overlay district.
- For additional information call Plan Review at 651-266-9007 or go to www.stpaul.gov



CITY OF SAINT PAUL

375 Jackson Street, Suite 220
Saint Paul, Minnesota 55101-1806

Telephone: 651-266-9007
Facsimile: 651-266-9124
Web: www.stpaul.gov/dsi

GARAGE INSPECTION PROCEDURE

(YOUR INSPECTOR'S NAME AND PHONE NUMBER IS INDICATED ON THE PERMIT CARD)

1. Footing / Concrete Slab-

To be made after all form work is set up and reinforcement is in place, but **PRIOR TO POURING OF CONCRETE**. Property owner/contractor is responsible for providing proof of property boundaries by locating existing property markers or by a registered land surveyor.

2. Framing-

To be made after all framing, blocking, bracing, bolts, and rough electrical (if applicable see electrical handout attached) are in place and secured. Engineered certified truss drawings shall be on site at the time of inspection.

3. Fire Rated Wall Assembly (if applicable)-

To be made after all Fire-Resistive materials are in place and before the sheathing and siding is placed on the exterior of the rated wall.

4. Final-

To be made upon completion of the garage and finish grade.

5. Other Inspections-

In addition to the inspections above, the inspector may make or require other inspections to ascertain compliance with the provisions of the code or to assist you with questions or concerns during the construction process.

ELECTRICITY IN YOUR NEW GARAGE?

AN ELECTRICAL PERMIT IS REQUIRED. SEE SEPARATE HANDOUT ATTACHED.

Any electrical questions, please call, 651-266-9003.

Building Height Measurements (63.501)

(Detached Garages and other Accessory Structures.)

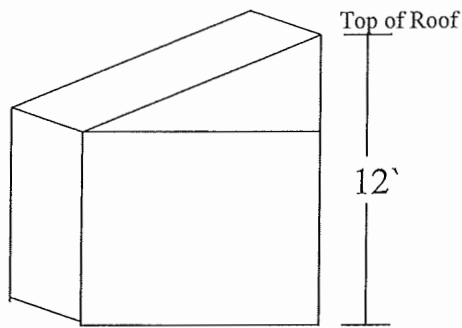

SHED

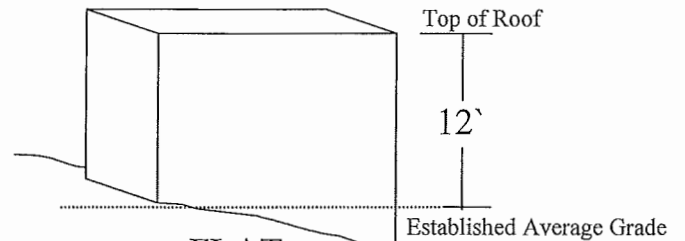

FLAT

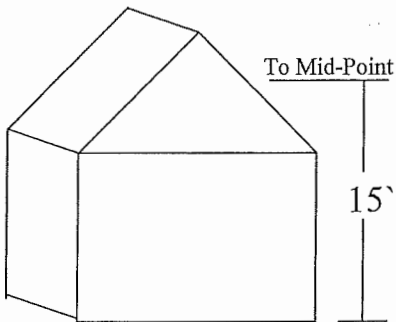

GABLE

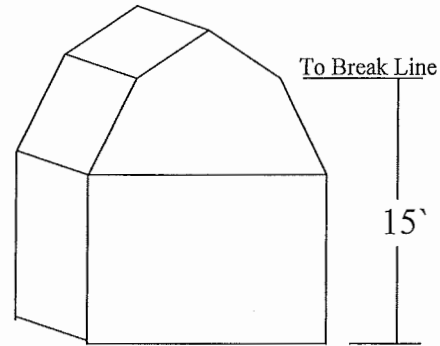

GAMBREL

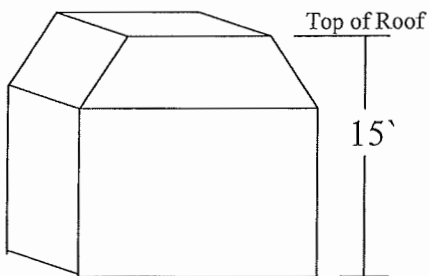

MANSARD

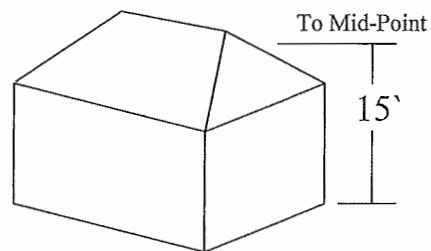

HIP

(Sec. 60.203) Building height. The vertical distance measured from the established grade to the highest point of the roof surface for flat and shed roofs; to the break line of mansard roofs; and to the average height between eaves and ridge for gable, gambrel, and hip roofs. Where a building is located on sloping terrain, the height may be measured from the average ground level of the grade at the building wall. The existing grade of the property shall not be raised around a new building or foundation in order to comply with the height requirements of this code. When there is a dormer built into the roof, the height is measured to the midpoint of the dormer roof if the dormer(s) roof width exceeds fifty (50) percent or more of the building roof width on the side where the dormer(s) is located.



**DETACHED GARAGES
SHEDS & RESIDENTIAL ACCESSORY STRUCTURES
(Sec. 63.501 Accessory buildings)**

Accessory buildings, except as otherwise provided in this code, shall be subject to the following regulations:

(a) When the accessory building is structurally attached to a main building, it shall be subject to, and must conform to, all regulations of this code applicable to main buildings.

(b) Accessory buildings, structures or uses shall not be erected in or established in a required yard except a rear yard. The following additional standards shall apply to residential parking:

- (1) Access to off-street parking shall be from an abutting improved alley when available, except where it is determined in the review of a site plan application that there are circumstances unique to the property that make this impractical, unreasonable, or harmful to the public safety. On corner lots, access to parking may be from the side street.
- (2) Off-street parking spaces shall not be located within the front yard.
- (3) Garages shall be set back from the front lot line at least as far as the principal structure (in the case of attached garages, this refers to the non-garage part of the structure).
- (4) Except in the rear yard, garage doors that face a public street shall be no more than nine (9) feet in height and shall not exceed sixty (60) percent of the width of the principal structure facing the same street.
- (5) Passenger vehicles may be parked on an approved driveway in front or side yards provided the driveway leads to a legal parking space.

(c) On corner lots, accessory buildings, structures or uses shall be set back from the street a distance equal to that required of the principal structure.

When an accessory building, structure or use is constructed in a rear yard which adjoins a side yard or front yard, the accessory building, structure or use shall be set back from the interior lot line a distance equal to the minimum side yard required of the principal structure.

On all other lots, accessory buildings shall be set back at least three (3) feet from all interior lot lines, and overhangs shall be set back at least one-third (1/3) the distance of the setback of the garage wall or one (1) foot, whichever is greater.

(d) This setback requirement from all interior lot lines for accessory buildings in rear yards shall be waived when a maintenance easement is recorded as to the affected properties, when proof of such recorded easement is provided at the time of application for a building permit and when the accessory building is located at least three (3) feet from any building on an adjoining lot. The recording of the maintenance easement shall be interpreted to mean that the following intents and purposes of this setback requirement are met:

- (1) Adequate supply of sunlight and air to adjacent property;
- (2) Sufficient space for maintenance of the building from the same lot; and
- (3) Prevention of damage to adjoining property by fire or runoff from roofs.

A recorded common wall agreement is permitted in lieu of a maintenance easement if the accessory structure is attached to an accessory structure on an adjoining lot.

(e) In any residential area, accessory buildings shall not exceed fifteen (15) feet in height; provided, however, that accessory buildings with a flat or shed roof style shall not exceed twelve (12) feet in height. Carriage house dwellings shall not exceed twenty-five (25) feet in height.

Exception: Accessory building heights shall not apply to property within designated heritage preservation districts nor to designated historic sites. In these cases appropriate building heights for accessory structures shall be determined through the design review process to ensure that heights are acceptable and in keeping with scale and style of development on the property.

(f) Accessory buildings on a zoning lot may occupy up to thirty-five (35) percent of the rear yard. Rear yards which adjoin alleys may include half the area of the alley to calculate the area of the rear yard which may be occupied by accessory buildings.

On zoning lots containing one- and two-family dwellings, there shall be a maximum of three (3) accessory buildings, the total of which shall not occupy more than one thousand (1,000) square feet of the zoning lot. On zoning lots containing all other uses, accessory buildings may occupy the same percent of the zoning lot as main buildings are allowed to occupy in the zoning district.

(g) In those instances where a lot line adjoins an alley right-of-way, the accessory building shall not be closer than one foot to such lot line.

(h) On through lots, where frontage is clearly established within a given block, rear yard setbacks shall be equal to the side yard setback required of the principal structure.

(i) Accessory buildings shall be located at least six (6) feet from the principal structure or shall be considered attached for purposes of the zoning code.

12/23/2009

Section R302, Fire-Resistant Construction.

Exterior walls: Exterior walls with a fire separation distance less than 5' shall have not less than 1-hour fire-resistive rating with exposure from both sides.

Projections: Projections extending into the fire separation distance shall have not less than 1-hour fire-resistive construction on the underside. Detached garages accessory to a dwelling located with 2 feet of a lot line are permitted to have roof eave projections not exceeding 4 inches. The above provisions shall not apply to walls which are perpendicular to the line used to determine the fire separation distance.

(Clarification: 1-hour fire-resistive rating with exposure from both sides is a layer of 5/8" TYPE X gypsum on the interior and exterior of the wall assembly.(see description below) All projections into the 5' separation distance must have 5/8" TYPE X gypsum on the soffit and a solid fascia board at the end of the rafters. No projections are allowed to be closer than 2' from the property line.)

Exception: Detached tool and storage sheds, playhouses and similar structures exempted from permits by Minnesota Rules, Chapter 1300 are not required to provide wall protection based on location on the lot. Projections beyond the exterior wall shall not extend over the lot line.

Openings: Openings shall not be permitted in the exterior wall of a dwelling unit or accessory building with a fire separation distance less than 3'. This distance shall be measured perpendicular to the line used to determine the fire separation distance.

Exceptions:

1. Openings shall be permitted in walls that are perpendicular to the line used to determine the fire separation distance.
2. Foundation vents installed in compliance with this code are permitted.

Penetrations: Penetrations located in the exterior wall of a dwelling with a fire separation distance less than 5 feet shall be protected in accordance with Section R302.4

Exception: Penetrations shall be permitted in walls that are perpendicular to the line used to determine the fire separation distance.

Example:

EXTERIOR WALLS	WOOD FRAMED
1 Hour Fire-rated Construction	

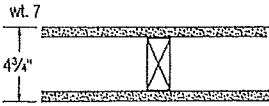
Construction Detail	Description	Test Number	ARL	Index
	<p>-5/8" Sheetrock brand type X exterior sheathing or 5/8 Firerock brand aqua-tough exterior sheathing</p> <p>-5/8" Sheetrock brand firecode core gypsum panels or Sheetrock brand water resistant firecode core gypsum panels, interior side</p> <p>-2x4 wood studs 16" o.c.</p> <p>-joints exposed or finished</p>	<p>UL Des U305, U314</p>	<p>SA700</p>	<p>F-23</p>



CITY OF SAINT PAUL

375 Jackson Street, Suite 220,
Saint Paul, Minnesota 55101-1806

Telephone: 651-266-9007
Facsimile: 651-266-9124
Web: www.stpaul.gov/dsi

REQUIREMENTS FOR CONSTRUCTION OF A DETACHED GARAGE

(Per 2015 Minnesota Residential Code [IRC])

A permitted detached accessory building may be constructed on a floating slab or an approved foundation provided:

1. All organic material is removed from the construction limits.
2. All concrete exposed to freezing or salt must be air-entrained. Code requires 5%-7% air-entrainment. Tell the dispatcher when you order ready-mix.
3. Calcium chloride setting accelerator in concrete may not be used in concentrations greater than 1/10%. Recommended practice is none. Non-chloride accelerators are allowed.
4. Concrete slab shall be a minimum of 3 1/2" thick with the perimeter of the slab 12" thick, and 12" wide poured in a monolithic manner. The garage floor area used for vehicular parking must be sloped to provide drainage toward the vehicle entry doorway or to a drainage system approved by this Office.
5. Concrete slab to be at least 3500 P.S.I. compressive strength with air entrainment per Item 2. If wire mesh is used it should be epoxy coated. Fiber-reinforced concrete is allowed.
6. Anchor bolts shall be a minimum 1/2" diameter, maximum 1' from the corner with a minimum of 2 anchor bolts per plate. The anchor bolts shall be spaced a maximum of 6' on center, embedded 7" into poured concrete or grouted into concrete block. Anchor straps are acceptable when installed according to the manufacturer's specifications.
7. NOTE: Garages with unbalanced fill against the outer wall (i.e.- finished grade higher than the top of the slab) will require a plan showing a cross-section through the wall that indicates how the wall is connected to the footing or slab and how the wall will be reinforced. This is especially important when the wall is not continuous (ex: 1/2 concrete block and 1/2 wood frame) since the lower portion must act as a retaining wall.
8. Bottom plates less than 8" from exposed ground are to be minimum 2" X 4" redwood or decay resistive treated. Top plates (2) must be double-lapped at corners and splices must be staggered a minimum of 24". Maintain 6" minimum clearance between the soil and wood.
9. Walls shall be sheathed with 1 1/16" nominal thickness boards, or 1/2" fiberboard, 1/2" nominal composite wood panels or other material approved by Code.
10. Roof trusses, when used, shall be engineered and pre-manufactured.
11. Roof sheathing may be 1" nominal thickness lumber, 7/16" CDX plywood, or other approved material. 7/16" plywood or similar with span rating of 24/0, supported on 24" centers, requires H-clips on all horizontal joints centered in each rafter bay.
12. Approved shingles or wood shingles to be applied according to Chapter 9 of the IRC or to the manufacturer's recommendation.
13. Garages which front on an alley are required to have contrasting house numbers posted, visible from the alley, the same as the house has on the street side.
14. Garage walls closer than 5 feet to an interior property line must be of 1-hour fire-resistive construction with exposure from both sides. Eave projections between 2 and 5 feet from the property line must be 1-hour rated on the underside. Eaves are not allowed closer than 2 feet to the line.

ATTACHED GARAGES

1. Garages attached to the principal structure (house) shall be constructed per the house's construction requirements and have continuous footings 42" below grade. Complete construction plans are required for attached garages.
2. Walls separating the house and garage shall be 1-hour fire rated and not be less than 1/2" gypsum wallboard applied on the garage side. Openings between the garage and residence shall be equipped with solid wood doors not less than 1 3/8" thick, solid or honeycomb-core steel doors not less than 1 3/8" thick, or 20 minute fire rated doors.

ALL CONSTRUCTION MUST MEET 2015 MINNESOTA RESIDENTIAL CODE. (See below)

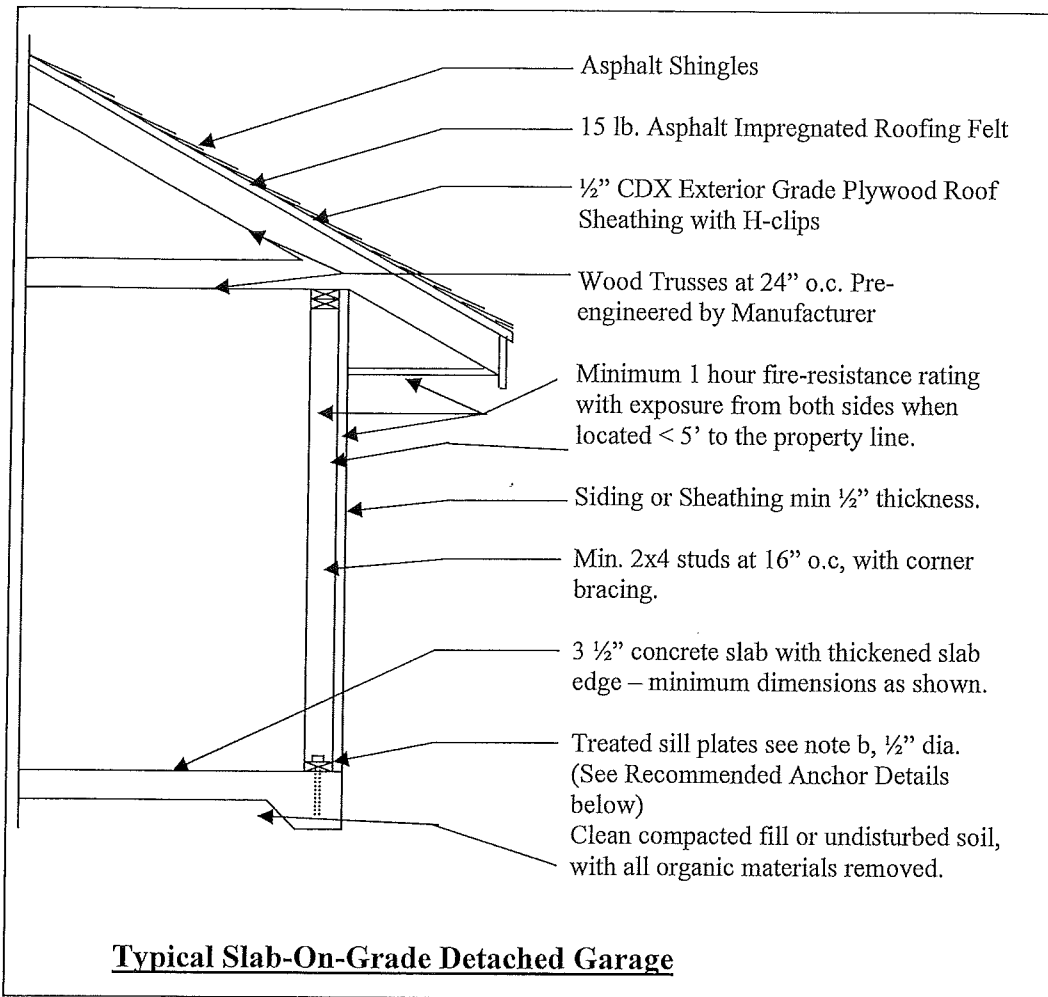

Garage Door Headers:
(For 16'-0" Door Opening)

No Roof Load = (2)-2x12's

Hip Roof = (2)-2x14's

Full Roof Load = (3)-
2x14's (#1 Douglas fir or
Engineered Beam)

Note: 18'-0" or larger garage
door openings require special
design.

Narrow Wall Design:

*Walls adjacent to garage
door openings that are less
than 48" in width require
consideration to bracing.*

*Walls adjacent to garage
door openings that are 24"
or less in width require
consideration to bracing
and hold downs.
(See narrow wall detail)*

Other Notes to Garage Construction:

- A) New "curb cuts" in the public way require a permit from Public Works. Public Works: (651) 266-6120.
- B) Wood on concrete or masonry in direct contact with the earth shall be treated or decay resistant, as well as sills or plates less than 8" from exposed ground, and siding, sheathing or wall framing less than 6" from grade.
- C) Garages adjacent to alleys are required to have contrasting house numbers posted, clearly visible from the alley.
- D) Alterations to existing topography shall provide drainage on-site to the public way.
- E) Contractors/owners are responsible for controlling erosion and run-off during construction and until landscaping is stabilized.
- F) Roof eave/overhangs must be at least 2 feet from adjacent private property. Roof run-off shall be controlled within the owner's property.
- G) No openings within <3 feet of the property line and only 25% from 3 to 5 feet.
- H) Roof eave/overhangs closer than 5' to the property lines must have 5/8" type X gypsum sheathing on the under side for fire protection.
- I) Garage doors, exterior doors, wall coverings, curtain walls, roof coverings, exterior windows, skylights and asphalt shingles shall be designed for 90 mph wind speed.

RECOMMENDED ANCHOR DETAILS

Other approved alternatives may be acceptable

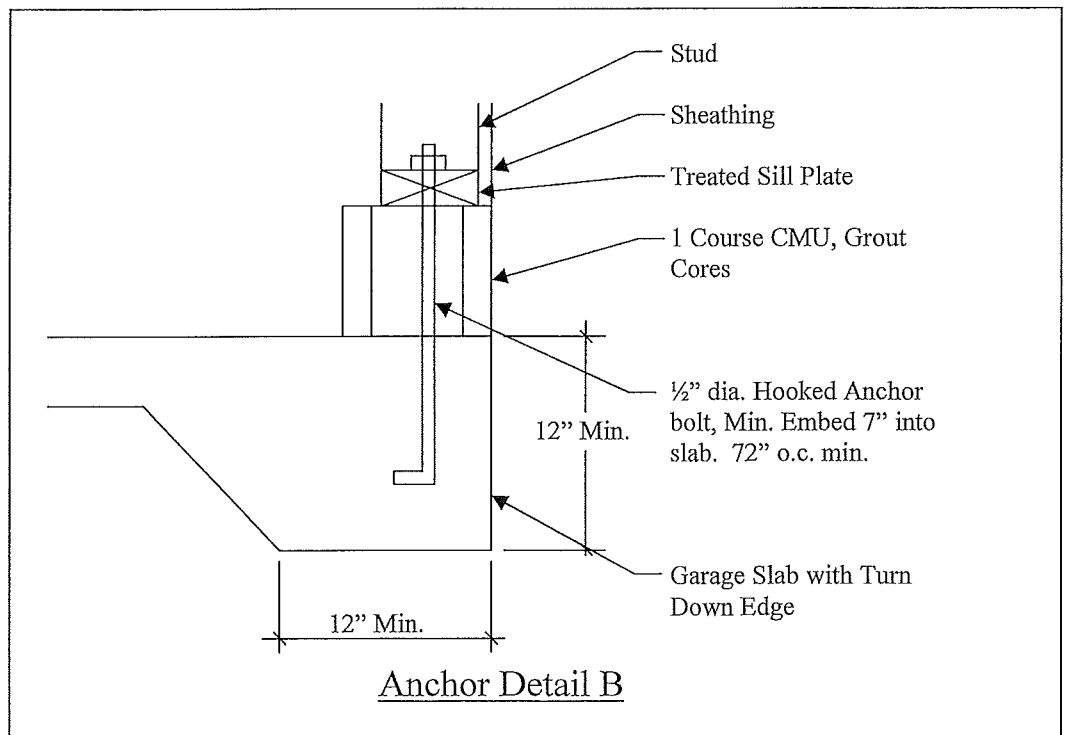
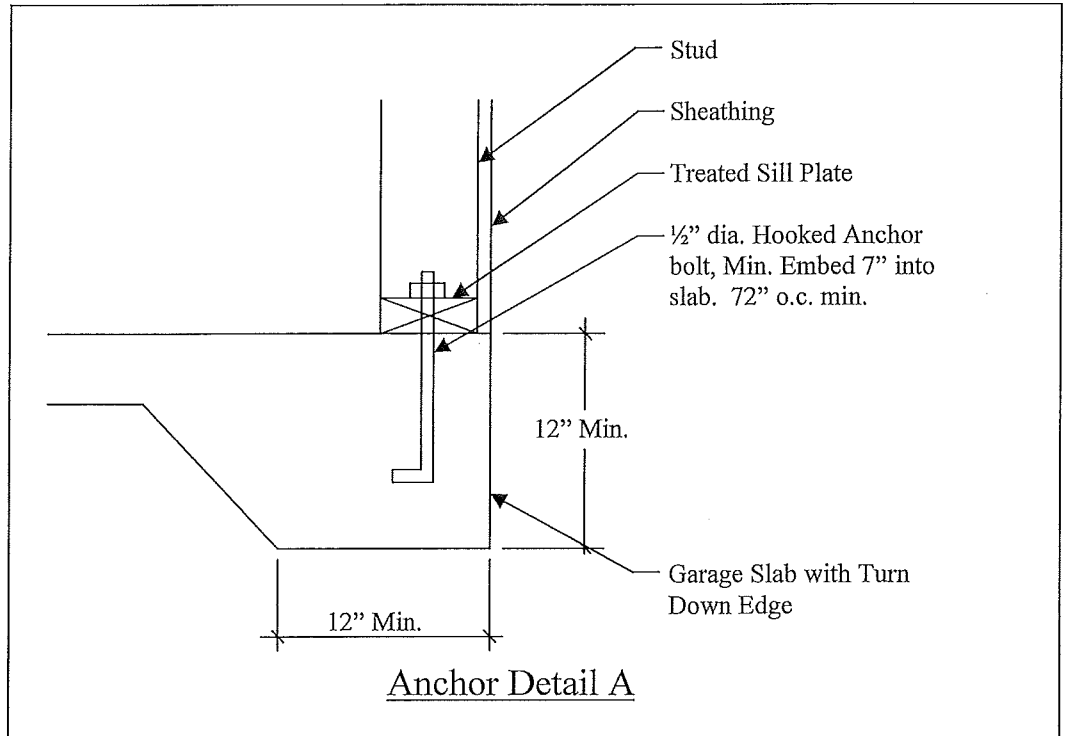

RECOMMENDED ANCHOR DETAILS (Cont)

Other approved alternatives may be acceptable

